

Receiver Driers

054-00001



Diameter: 2-1/2"
Height: 8"
Inlet: #6 Male Insert O-Ring
Outlet: #6 Male Insert O-Ring

054-00006



Diameter: 2-1/2"
Height: 6-1/4"
Inlet: #6 Male Insert O-Ring
Outlet: 1/2" Male

Outlet Fits Quick Connect Couplings 050-00030 or 050-00034

1991-1992 General Motors RV Chassis GM#15547182 or 15665139

054-00010



Diameter: 2-1/2"
Height: 8"
Inlet: #6 Male Insert O-Ring
Outlet: #6 Male Insert O-Ring

With R-12 Service Port (7/16" Thread) and 3/8" Switch Port

054-00011



Diameter: 2-1/2"
Height: 8"
Inlet: #6 Male Insert O-Ring
Outlet: 1/2" Male

Outlet Fits Quick Connect Couplings 050-00380 or 050-0034

054-00015



Diameter: 2-1/2"
Height: 6-1/4"
Inlet: 18mm Male Insert O-Ring
Outlet: 12mm Male
With 10mm Switch Port

Outlet Fits Quick Connect Couplings 050-00120 or 050-00148

054-00019



Diameter: 2-1/2"
Height: 8"
Inlet: #6 Male Insert O-Ring
Outlet: #6 Male Insert O-Ring

With 032-00048 Binary Pressure Switch

Receiver Driers

054-00022



Diameter: 3"
 Height: 10-3/8"
 Inlet: #6 Male Insert O-Ring
 Outlet: #6 Male Insert O-Ring

With R-12 Service Port (7/16" Thread)

054-00134



Diameter: 2-1/2"
 Height: 6-1/4"
 Inlet: 18mm Male Insert O-Ring
 Outlet: 12mm Male
 With 10mm Switch Port
 Outlet Fits Quick Connect Couplings 050-00120 or 050-00148

1994 and later GM or WorkHorse RV Chassis GM#12375979 or 12546083

054-00135



Diameter: 2-1/2"
 Height: 6-1/4"
 Inlet: 18mm Male Insert O-Ring
 Outlet: 18mm Male Insert O-Ring
 With 10mm Switch Port

1994 and later GM or WorkHorse RV Chassis GM#12375380 or 12548454

054-00138



Diameter: 2-1/2"
 Height: 6-1/4"
 Inlet: 18mm Male Insert O-Ring
 Outlet: 1/2" Male
 With 10mm Switch Port Outlet Fits
 Quick Connect
 Couplings 050-00030 or 050-00034

1993 General Motors RV Chassis GM#12542121 or 12546135

054-00139



Diameter: 2-1/2"
 Height: 6-1/4"
 Inlet: 18mm Male Insert O-Ring
 Outlet: 12mm Male
 With 10mm Switch Port—Outlet Fits Quick Connect Couplings
 050-00120 or 050-00148

2000 and later WorkHorse RV Chassis

054-00140



Diameter: 2-1/2"
 Height: 6-1/4"
 Inlet: 18mm Male Insert O-Ring
 Outlet: 18mm Male Insert O-Ring
 With 10mm Switch Port

2000 and later WorkHorse RV Chassis

DRIER QC FTGS

MOTORHOME LIQUID LINE QUICK CONNECT FITTINGS

STANDARD 1/2" THREAD - FORD AND SCS PUSHER UNITS (EXCEPT WINNEBAGO)

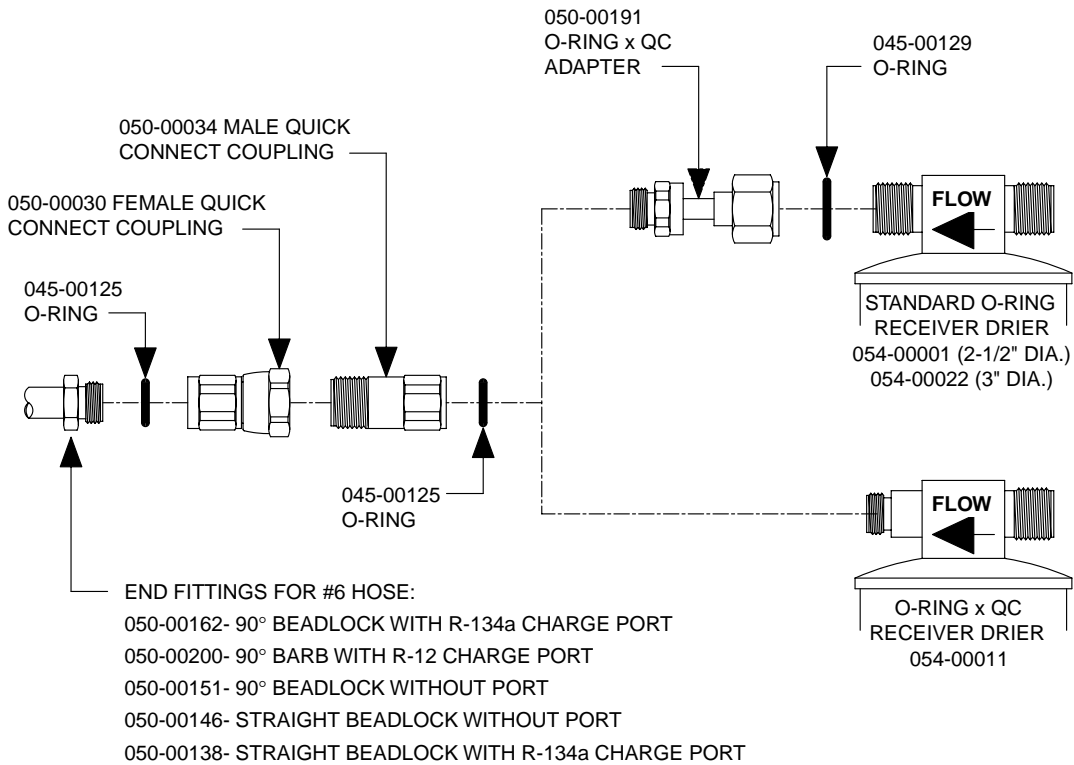

METRIC THREAD - GM, WCC, FREIGHTLINER, AND SCS WINNEBAGO PUSHER UNITS

